

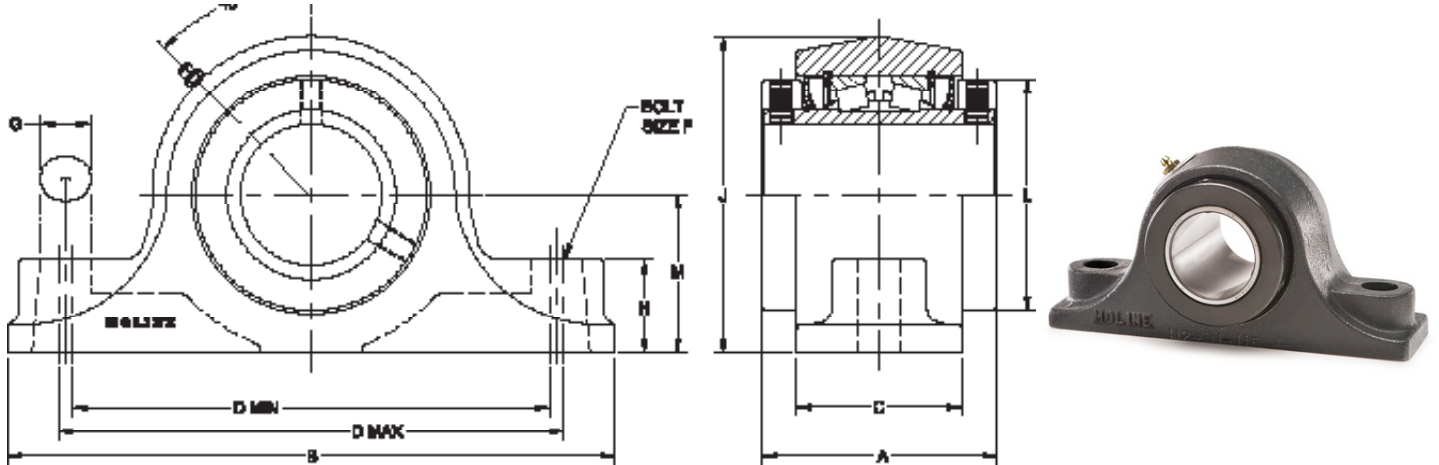

# MOLINE BEARING CO.

## 19321208 Type E 2-Bolt Pillow Block

MADE IN THE USA WITH TIMKEN® DEE TAPERED ROLLER BEARINGS



SHAFT SIZE	MOLINE PART #	DIMENSIONS (INCHES)												WEIGHT LBS.
		A	B	C	MIN D	CENTER TO CENTER D	MAX D	F	G	H	J	L	M	
2 1/2	19321208	4	10 1/2	2 7/8	7 1/8	7 7/8	8 5/8	5/8	1 1/2	1 5/8	5 11/16	4	2 3/4	19

SHAFT SIZES	MINIMUM HOURS LIFE*	RADIAL LOAD RATINGS AT VARIOUS REVOLUTIONS PER MINUTE									
		50	100	150	250	500	750	1000	1200	1360	1530
2 1/2	10000	16129	13100	11600	9952	8083	7158	6566	6216	5987	5779
	30000	11600	9422	8343	7158	5814	5148	4722	4471	4306	4157
	40000	10641	8643	7653	6566	5333	4722	4332	4101	3950	3813
	60000	9422	7653	6777	5814	4722	4181	3836	3631	3498	3376
	100000	8083	6566	5814	4988	4051	3587	3291	3116	3001	2897

SHAFT SIZES	RADIAL LOAD RATINGS AT VARIOUS REVOLUTIONS PER MINUTE								
	1640	1750	2060	2420	2730	3050	3320	3820	4490
2 1/2	5660	5551	5286	5037	----	----	----	----	----
	4071	3992	3802	3622	----	----	----	----	----
	3734	3662	3487	3323	----	----	----	----	----
	3307	3243	3088	2942	----	----	----	----	----
	2837	2782	2649	2524	----	----	----	----	----

SHAFT SIZE	MAXIMUM RPM LABYRINTH SEAL	MAXIMUM RPM CONTACT SEAL
2 1/2	2420	2100

CAD drawings available upon request at no additional charge (cadlibrary@molinebearing.com).