

# Variable Pitch Sheaves

## 1 Groove

Part No.	Type	Diameter Range												Stock Bores Marked x									
		3L Belts				4L or A Belts				5L or B Belts				1/2	5/8	3/4	7/8	1	1 1/8	1 1/4	1 3/8	1 5/8	
		Min. Pitch	Turns Open	Max. Pitch	Turns Open	Min. Datum	Turns Open	Max. Datum	Turns Open	Min. Datum	Turns Open	Max. Datum	Turns Open										
1VP25	1	1.6	4	2.4	0	—	—	—	—	—	—	—	—	x	—	—	—	—	—	—	—	—	
1VP30	1	1.8	4	2.7	0	—	—	—	—	—	—	—	—	x	x	x	x	—	—	—	—	—	
1VP34	1	1.7	4	2.5	0	1.9	5	2.9	0	2.4	5	3.2	1	x	x	x	x	—	—	—	—	—	
1VP40	1	2.3	4	3.1	0	2.4	5	3.4	0	2.7	6	3.7	1	x	x	x	x	—	—	—	—	—	
1VP44	1	2.7	4	3.5	0	2.8	5	3.8	0	3.1	6	4.1	1	x	x	x	—	—	—	—	—		
1VP44	2	2.7	4	3.5	0	2.8	5	3.8	0	3.1	6	4.1	1	—	—	—	x	x	x	—	—		
1VP50	1	3.3	4	4.1	0	3.4	5	4.4	0	3.7	6	4.7	1	x	x	x	—	—	—	—	—		
1VP50	2	3.3	4	4.1	0	3.4	5	4.4	0	3.7	6	4.7	1	—	—	—	x	x	x	—	—		
1VP56	1	3.9	4	4.7	0	4.0	5	5.0	0	4.3	6	5.3	1	x	x	x	—	—	—	—	—		
1VP56	2	3.9	4	4.7	0	4.0	5	5.0	0	4.3	6	5.3	1	—	—	—	x	x	x	—	—		
1VP60	2	—	—	—	—	4.2	5	5.2	0	4.3	6	5.5	0	—	—	—	x	x	—	x	—		
1VP62	2	4.5	4	5.3	0	4.6	5	5.6	0	4.9	6	5.9	1	—	x	x	x	x	x	x	—		
1VP65	2	—	—	—	—	4.7	5	5.7	0	4.8	6	6.0	0	—	—	—	x	x	—	x	—		
1VP68	2	5.1	4	5.9	0	5.2	5	6.2	0	5.5	6	6.5	1	—	x	x	x	x	x	x	—		
1VP71	2	—	—	—	—	5.3	5	6.3	0	5.4	6	6.6	0	—	—	—	x	x	—	x	—		
1VP75	2	—	—	—	—	5.7	5	6.7	0	5.8	6	7.0	0	—	—	—	x	x	—	x	—		

Part No.	Type	O.D.	F		G		L	K	Wt. (Lbs.)
			Max.	Min.	Max.	Min.			
1VP25	1	2.5	13/16	9/16	5/8	3/8	1 1/2	5/8	0.7
1VP30	1	2.87	13/16	9/16	5/8	3/8	1 21/32	19/32	1.1
1VP34	1	3.15	1	11/16	13/16	1/2	1 7/8	21/32	1.4
1VP40	1	3.75	1 1/16	11/16	7/8	1/2	1 7/8	21/32	1.9
1VP44	1	4.15	1 1/16	11/16	7/8	1/2	1 7/8	21/32	2.4
1VP44	2	4.15	1 1/8	3/4	7/8	1/2	1 7/8	11/16	2.9
1VP50	1	4.75	1 1/16	11/16	7/8	1/2	2	25/32	2.9
1VP50	2	4.75	1 1/8	3/4	7/8	1/2	1 7/8	11/16	3.6
1VP56	1	5.35	1 1/16	11/16	7/8	1/2	1 7/8	21/32	3.8
1VP56	2	5.35	1 1/8	3/4	7/8	1/2	1 7/8	11/16	4.4
1VP60	2	6.00	1 1/4	7/8	1 1/32	21/32	1 21/32	7/16	6.5
1VP62	2	5.95	1 1/8	3/4	7/8	1/2	1 29/32	21/32	6.1
1VP65	2	6.50	1 1/4	7/8	1 1/32	21/32	1 21/32	7/16	6.8
1VP68	2	6.55	1 1/8	3/4	7/8	1/2	1 29/32	21/32	7.3
1VP71	2	7.10	1 1/4	7/8	1 1/32	21/32	1 21/32	7/16	8.2
1VP75	2	7.50	1 1/4	7/8	1 1/32	21/32	1 21/32	7/16	9.2

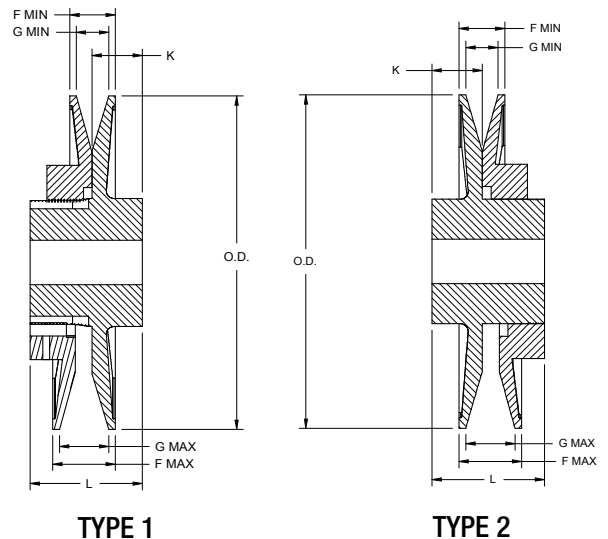

All dimensions in inches.