

Variable Pitch Sheaves

2 Groove

Part No.	Type	Diameter Range												Stock Bores Marked x								
		3L Belts				4L or A Belts				5L or B Belts				1/2	5/8	3/4	7/8	1	1 1/8	1 1/4	1 3/8	1 5/8
		Min. Pitch	Turns Open	Max. Pitch	Turns Open	Min. Datum	Turns Open	Max. Datum	Turns Open	Min. Datum	Turns Open	Max. Datum	Turns Open									
2VP36	4	1.9	4	2.7	0	2.0	5	3.0	0	2.5	5	3.3	1	x	x	x	x	x	—	—	—	—
2VP42	4	2.5	4	3.3	0	2.6	5	3.6	0	2.9	6	3.9	1	—	x	x	x	x	x	—	—	—
2VP50	5	3.3	4	4.1	0	3.4	5	4.4	0	3.7	6	4.7	1	—	x	x	x	x	x	—	—	—
2VP56	5	3.9	4	4.7	0	4.0	5	5.0	0	4.3	6	5.3	1	—	x	x	x	x	x	—	—	—
2VP60	5	—	—	—	—	4.2	5	5.2	0	4.3	6	5.5	0	—	—	x	x	—	x	—	x	—
2VP62	5	4.5	4	5.3	0	4.6	5	5.6	0	4.9	6	5.9	1	—	—	x	x	x	x	x	x	—
2VP65	5	—	—	—	—	4.7	5	5.7	0	4.8	6	6.0	0	—	—	x	x	—	x	—	x	—
2VP68	5	5.1	4	5.9	0	5.2	5	6.2	0	5.5	6	6.5	1	—	—	x	x	x	x	x	x	—
2VP71	5	—	—	—	—	5.3	5	6.3	0	5.4	6	6.6	0	—	—	x	x	—	x	—	x	—
2VP75	5	—	—	—	—	5.7	5	6.7	0	5.8	6	7.0	0	—	—	x	x	—	x	—	x	—

Part No.	Type	O.D.	F		G		L	K	Wt. (Lbs.)
			Max.	Min.	Max.	Min.			
2VP36	4	3.35	2	1 3/8	13/16	1/2	3	1 3/16	3.4
2VP42	4	3.95	2 1/8	1 3/8	7/8	1/2	3	1 3/16	4.4
2VP50	5	4.75	2 1/8	1 3/8	7/8	1/2	3	1 3/16	6.3
2VP56	5	5.35	2 1/8	1 3/8	7/8	1/2	3	1 3/16	7.8
2VP60	5	6.00	2 3/8	1 5/8	1 1/32	21/32	3 1/4	1 1/4	10.6
2VP62	5	5.95	2 3/8	1 5/8	1 1/32	21/32	3	1 3/16	10.0
2VP65	5	6.50	2 3/8	1 5/8	1 1/32	21/32	3 1/4	1 1/4	12.3
2VP68	5	6.55	2 3/8	1 5/8	1 1/32	21/32	3	1 3/16	11.7
2VP71	5	7.10	2 3/8	1 5/8	1 1/32	21/32	3 1/4	1 1/4	14.6
2VP75	5	7.50	2 3/8	1 5/8	1 1/32	21/32	3 1/4	1 1/4	16.5

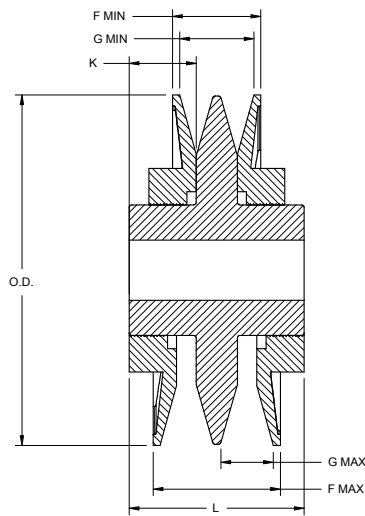

TYPE 4

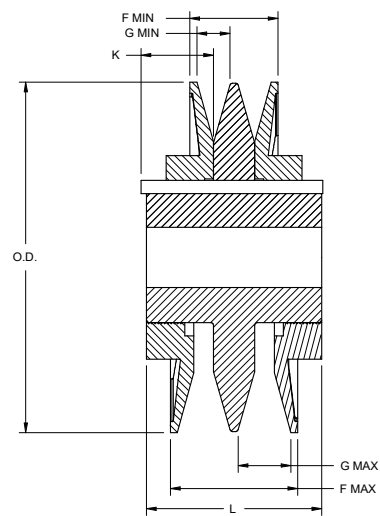

TYPE 5

All dimensions in inches.