

Single groove sheave: Combination sheave for "4L", "A", "5L" or "B" belts.

Part No.	Diameter			Type	Dimensions								Approx. Weight (lbs.)
	Outside O.D.	Pitch P.D. 4L/A	Pitch P.D. 5L/B		O.L.	F	L	P	C	X	G	E	
BK30H	3.15	2.40	2.80	1	1 15/16	7/8	1 1/4	7/8	—	1 5/16	7/16	3/16	1.2
BK32H	3.35	2.60	3.00	1	1 15/16	7/8	1 1/4	7/8	—	1 5/16	7/16	3/16	1.4
BK34H	3.55	2.80	3.20	1	1 15/16	7/8	1 1/4	7/8	—	1 5/16	7/16	3/16	1.6
BK36H	3.75	3.00	3.40	2	1 1/2	7/8	1 1/4	7/16	—	7/8	7/16	3/16	1.2
BK40H	3.95	3.20	3.60	2	1 1/2	7/8	1 1/4	7/16	—	7/8	7/16	3/16	1.4
BK45H	4.25	3.50	3.90	2	1 1/2	7/8	1 1/4	7/16	—	7/8	7/16	3/16	1.8
BK47H	4.45	3.70	4.10	2	1 1/2	7/8	1 1/4	7/16	—	7/8	7/16	3/16	2.2
BK50H	4.75	4.00	4.40	2	1 1/2	7/8	1 1/4	7/16	—	7/8	7/16	3/16	2.0
BK52H	4.95	4.20	4.60	2	1 1/2	7/8	1 1/4	7/16	—	7/8	7/16	3/16	2.1
BK55H	5.25	4.50	4.90	2	1 1/2	7/8	1 1/4	7/16	—	7/8	7/16	3/16	2.7
BK57H	5.45	4.70	5.10	2	1 1/2	7/8	1 1/4	7/16	—	7/8	7/16	3/16	2.7
BK60H	5.75	5.00	5.40	2	1 1/2	7/8	1 1/4	7/16	—	7/8	7/16	3/16	2.5
BK62H	5.95	5.20	5.60	2	1 1/2	7/8	1 1/4	7/16	—	7/8	7/16	3/16	2.6
BK65H	6.25	5.50	5.90	2	1 1/2	7/8	1 1/4	7/16	—	7/8	7/16	3/16	2.8
BK67H	6.45	5.70	6.10	2	1 1/2	7/8	1 1/4	7/16	—	7/8	7/16	3/16	2.9
BK70H	6.75	6.00	6.40	3	1 9/16	7/8	1 1/4	1/2	1/16	7/8	7/16	3/16	2.8
BK72H	6.95	6.20	6.60	3	1 9/16	7/8	1 1/4	1/2	1/16	7/8	7/16	3/16	3.1
BK75H	7.25	6.50	6.90	3	1 9/16	7/8	1 1/4	1/2	1/16	7/8	7/16	3/16	3.3
BK77H	7.45	6.70	7.10	3	1 9/16	7/8	1 1/4	1/2	1/16	7/8	7/16	3/16	3.8
BK80H	7.75	7.00	7.40	3	1 9/16	7/8	1 1/4	1/2	1/16	7/8	7/16	3/16	3.4
BK85H	8.25	7.50	7.90	3	1 9/16	7/8	1 1/4	1/2	1/16	7/8	7/16	3/16	3.8
BK90H	8.75	8.00	8.40	3	1 9/16	7/8	1 1/4	1/2	1/16	7/8	7/16	3/16	4.3
BK95H	9.25	8.50	8.90	3	1 9/16	7/8	1 1/4	1/2	1/16	7/8	7/16	3/16	5.0
BK100H	9.75	9.00	9.40	3	1 9/16	7/8	1 1/4	1/2	1/16	7/8	7/16	3/16	5.2
BK105H	10.25	9.50	9.90	3	1 9/16	7/8	1 1/4	1/2	1/16	7/8	7/16	3/16	5.5
BK110H	10.75	10.00	10.40	3	1 9/16	7/8	1 1/4	1/2	1/16	7/8	7/16	3/16	6.0
BK115H	11.25	10.50	10.90	3	1 9/16	7/8	1 1/4	1/2	1/16	7/8	7/16	3/16	6.4
BK120H	11.75	11.00	11.40	3	1 9/16	7/8	1 1/4	1/2	1/16	7/8	7/16	3/16	6.9
BK130H	12.75	12.00	12.40	3	1 9/16	7/8	1 1/4	1/2	1/16	7/8	7/16	3/16	6.9
BK140H	13.75	13.00	13.40	3	1 9/16	7/8	1 1/4	1/2	1/16	7/8	7/16	3/16	8.5
BK150H	14.75	14.00	14.40	3	1 9/16	7/8	1 1/4	1/2	1/16	7/8	7/16	3/16	9.5
BK160H	15.75	15.00	15.40	3	1 9/16	7/8	1 1/4	1/2	1/16	7/8	7/16	3/16	9.8
BK190H	18.75	18.00	18.40	3	1 9/16	7/8	1 1/4	1/2	1/16	7/8	7/16	3/16	12.8

Please refer to pages 105-106 for bushing dimensions

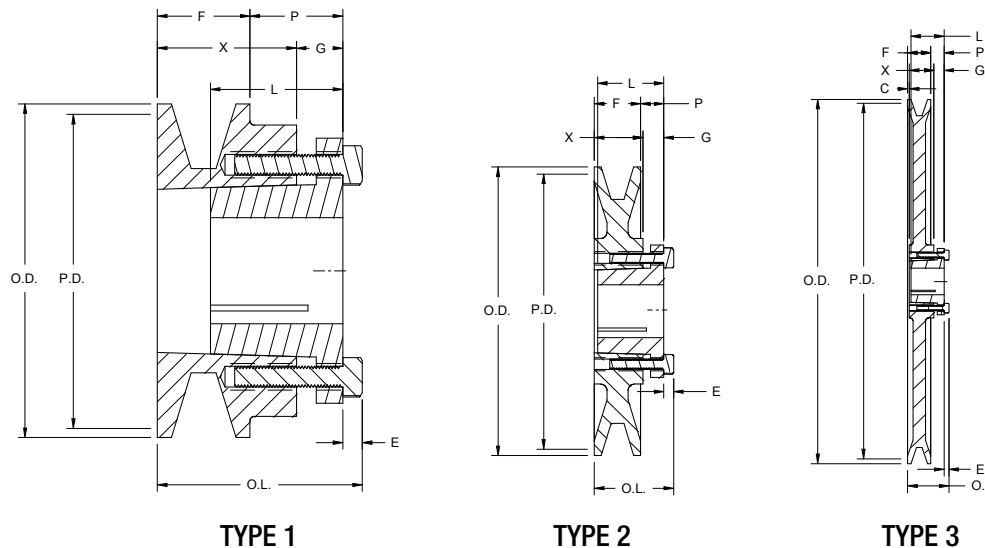

### Stock H Bushings

Stock Bores	Keyseats
3/8	None
7/16	None
1/2	1/8 x 1/16
9/16	1/8 x 1/16
5/8	3/16 x 3/32
11/16	3/16 x 3/32
3/4	3/16 x 3/32
13/16	3/16 x 3/32
7/8	3/16 x 3/32
15/16	1/4 x 1/8
1	1/4 x 1/8
1 1/16	1/4 x 1/8
1 1/8	1/4 x 1/8
1 3/16	1/4 x 1/8
1 1/4	1/4 x 1/16*
1 5/16	5/16 x 1/16*
1 3/8	5/16 x 1/16*
1 3/8	3/8 x 1/16*
1 7/16	3/8 x 1/16*
1 1/2	3/8 x 1/16*

### Millimeter Bores

10	None
11	None
12	None
14	5 x 2.5
16	5 x 2.5
18	6 x 3.0
19	6 x 3.0
20	6 x 3.0
22	6 x 3.0
24	8 x 3.5
25	8 x 3.5
28	8 x 3.5
30	8 x 3.5
32	10 x 4.0
35	10 x 4.0
36	10 x 4.0
38	10 x 4.0

### Stock Spline Bores

.978 - 10 Inv.	x
1 1/8 - 6B	x
1 3/8 - 6B	x
1 3/8 - 21 Inv.	x

Bushing Part numbers are specified by H and bore size. Example: H-1 1/8"

\*These sizes are furnished with special keys to fit standard depth keyseats.