

Setscrew Ball Bearings SCB NORMAL DUTY PILLOW BLOCKS

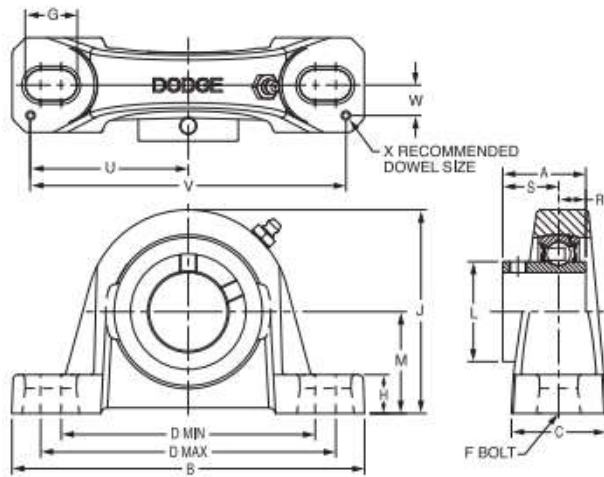

Lube Fitting

203 series - 1/4-28 tapered thread
204 series and larger - 1/8-27 NPT

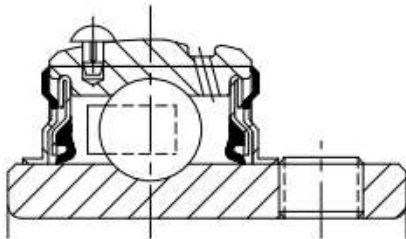

Series	Shaft Size	Part No.	Description
203 (SC)	1/2	123830	P2B-SC-008
	5/8	123831	P2B-SC-010
	17mm	053170	P2B-SC-17M
204	1/2	123854	P2B-SCB-008L
	5/8	123855	P2B-SCB-010L
	3/4	123860	P2B-SCB-012
	20mm	124941	P2B-SCB-20M
205	7/8	123861	P2B-SCB-014
	15/16	123862	P2B-SCB-015
	1	123863	P2B-SCB-100
	25mm	125768	P2B-SCB-25M
206	1-1/16	123856	P2B-SCB-101
	1-1/8	123864	P2B-SCB-102
	1-3/16	123865	P2B-SCB-103
	1-1/4	123171	P2B-SCB-104S
	30mm	125760	P2B-SCB-30M
207	1-1/4	123866	P2B-SCB-104
	1-5/16	123857	P2B-SCB-105
	1-3/8	123867	P2B-SCB-106
	1-7/16	123868	P2B-SCB-107
208	35mm	124944	P2B-SCB-35M
	1-1/2	123869	P2B-SCB-108
	1-5/8	123858	P2B-SCB-110
209	40mm	125856	P2B-SCB-40M
	1-5/8	068760	P2B-SCB-110L
	1-11/16	123870	P2B-SCB-111
	1-3/4	123871	P2B-SCB-112
210	45mm	051878	P2B-SCB-45M
	1-15/16	123872	P2B-SCB-115
	2	123873	P2B-SCB-200
211	50mm	051879	P2B-SCB-50M
	2	057603	P2B-SCB-200L
	2-3/16	123874	P2B-SCB-203
	2-1/4	123589	P2B-SCB-204
212	55mm	124943	P2B-SCB-55M
	2-1/4	068361	P2B-SCB-204L
	2-7/16	123875	P2B-SCB-207
215	60mm	051880	P2B-SCB-60M
	2-15/16	123727	P2B-SCB-215
	75mm	@	P2B-SCB-75M

Series	Shaft Size	Weight lbs. kgs.	A	B	C	D		F Bolt Dia	G	H	J	L	M	R	S	U	V	W	X	
						Min	Max													
203 SC	1/2	1.1	1.00	5.00	1.20	3.25	4.06	3/8	0.84	0.47	2.14	0.96	1.06	0.36	0.64	2.25	4.50	0.38	0.12	
	5/8	1.0																		
	17mm	0.4	25.4	127.0	30.5	82.6	103.1	M10	21.3	11.9	54.4	24.4	26.9	9.1	16.3	57.2	114.3	9.7	3.0	
204	1/2	1.6	1.23	5.25	1.34	3.38	4.19	3/8	0.85	0.47	2.49	1.12	1.25	0.50	0.73	2.25	4.50	0.50	0.12	
	5/8	1.5																		
	3/4	1.4																		
	20mm	0.7	31.2	133.4	34.0	85.9	106.4	M10	21.6	11.9	63.2	28.4	31.8	12.7	18.5	57.2	114.3	12.7	3.0	
205	7/8	1.8	1.34	5.50	1.40	3.69	4.50	3/8	0.85	0.45	2.64	1.32	1.31	0.56	0.78	2.50	5.00	0.50	0.12	
	15/16	1.7																		
	1	1.6																		
	25mm	.07	34.0	139.7	35.6	93.7	114.3	M10	21.6	11.4	67.1	33.5	33.3	14.2	19.8	63.5	127.0	12.7	3.0	
206	1-1/16	2.8	1.52	6.25	1.75	4.25	5.00	1/2	0.94	0.62	3.19	1.57	1.56	0.58	0.94	2.88	5.76	0.56	0.12	
	1-1/8	2.7																		
	1-3/16	2.6																		
	1-1/4	2.5																		
	30mm	1.1	38.6	158.8	44.5	108.0	127.0	M12	23.9	15.8	81.0	39.9	39.6	14.7	23.9	73.2	146.3	14.2	3.0	
207	1-1/4	4.5	1.71	6.50	1.75	4.68	5.44	1/2	0.94	0.65	3.69	1.84	1.81	0.67	1.04	2.91	5.82	0.56	0.12	
	1-5/16	4.4																		
	1-3/8	45.3																		
	1-7/16	4.2																		
	35mm	1.5	43.4	165.1	44.5	118.9	138.2	M12	23.9	16.5	93.7	46.7	46.0	17.0	26.4	73.9	147.8	14.2	3.0	
208	1-1/2	5.4	1.94	7.25	1.93	5.18	5.88	1/2	0.91	0.75	4.00	2.05	1.94	0.75	1.19	3.26	6.52	0.69	0.12	
	1-5/8	5.3																		
	40mm	2.2	49.3	184.2	49.0	131.6	149.4	M12	23.1	19.1	101.6	52.1	49.3	19.1	30.2	82.8	165.6	17.5	3.0	
209	1-5/8	6.6	1.94	7.44	2.00	5.50	6.19	1/2	0.90	0.69	4.21	2.22	2.06	0.75	1.19	3.38	6.76	0.69	0.12	
	1-11/16	6.4																		
	1-3/4	6.2																		
	45mm	2.2	49.3	189.0	50.8	139.7	157.2	M12	22.9	17.5	106.9	56.4	52.3	19.1	30.2	85.9	171.7	17.5	3.0	
210	1-15/16	78.2	1.94	8.12	2.25	6.00	6.68	5/8	1.02	0.68	4.47	2.43	2.19	0.75	1.19	3.69	7.38	0.81	0.12	
	2	7.0																		
	50mm	2.6	49.3	206.2	57.2	152.4	169.7	M16	25.9	17.3	113.5	61.7	55.6	19.1	30.2	93.7	187.5	20.6	3.0	
211	2	9.0	2.22	8.88	2.30	6.38	7.44	5/8	1.21	0.81	4.90	2.71	2.44	0.87	1.35	3.94	7.88	0.81	0.12	
	2-3/16	8.9																		
	2-1/4	8.8																		
	55mm	3.3	56.4	225.6	58.4	162.1	189.0	M16	30.7	20.6	124.5	68.8	62.0	22.1	34.3	100.1	200.2	20.6	3.0	
212	2-1/4	10.8	2.31	9.50	2.37	6.88	7.94	5/8	1.21	0.81	5.34	2.97	2.69	0.90	1.41	4.25	8.50	0.88	0.12	
	2-7/16	10.2																		
	60mm	4.2	58.7	241.3	60.2	174.8	201.7	M16	30.7	20.6	135.6	75.4	68.3	22.9	35.8	108.0	215.9	22.4	3.0	
215	2-15/16	20.5	2.33	11.75	2.88	8.50	9.50	7/8	1.44	1.06	6.56	3.62	3.31	0.86	1.47	5.48	10.96	1.04	0.12	
	75mm	7.9	59.2	298.5	73.2	215.9	241.3	M22	36.6	26.9	166.6	91.9	84.1	21.8	37.3	139.2	278.4	26.4	3.0	