

## Eccentric Collar Ball Bearings SXRb NORMAL DUTY PILLOW BLOCK

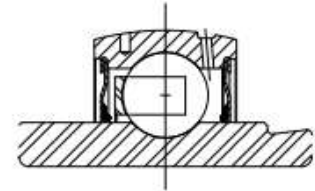
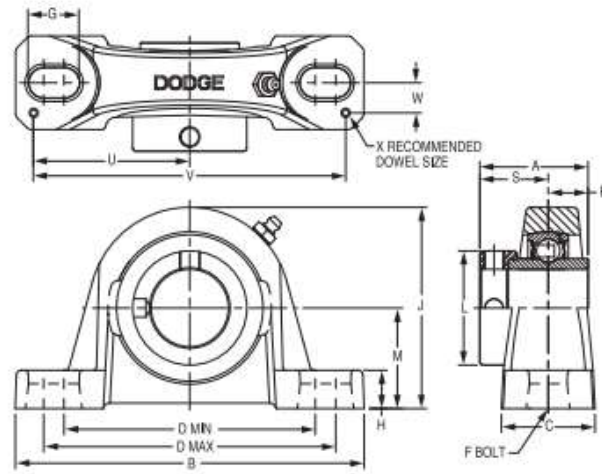

Series	Shaft Size	Standard		With Flingers	
		Part No.	Description	Part No.	Description
203 (SXR)	1/2	<b>131800</b>	P2B-SXR-008	@	P2B-SXR-008-FF
	5/8	<b>131801</b>	P2B-SXR-010	@	P2B-SXR-010-FF
	17mm	@	P2B-SXR-17M	@	P2B-SXR-17M-FF
204	3/4	<b>131830</b>	P2B-SXRb-012	<b>068195</b>	P2B-SXRb-012-FF
	20mm	@	P2B-SXRb-20M	@	P2B-SXRb-20M-FF
205	7/8	<b>131831</b>	P2B-SXRb-014	@	P2B-SXRb-014-FF
	15/16	<b>131832</b>	P2B-SXRb-015	@	P2B-SXRb-015-FF
	1	<b>131833</b>	P2B-SXRb-100	<b>068196</b>	P2B-SXRb-100-FF
	25mm	@	P2B-SXRb-25M	@	P2B-SXRb-25M-FF
206	1-1/16	<b>131834</b>	P2B-SXRb-101	@	P2B-SXRb-101-FF
	1-1/8	<b>131835</b>	P2B-SXRb-102	<b>068197</b>	P2B-SXRb-102-FF
	1-3/16	<b>131836</b>	P2B-SXRb-103	<b>068198</b>	P2B-SXRb-103-FF
	1-1/4	<b>068743</b>	P2B-SXRb-104S	@	P2B-SXRb-104S-FF
	30mm	@	P2B-SXRb-30M	@	P2B-SXRb-30M-FF
207	1-1/4	<b>131837</b>	P2B-SXRb-104	<b>068199</b>	P2B-SXRb-104-FF
	1-5/16	<b>131838</b>	P2B-SXRb-105	@	P2B-SXRb-105-FF
	1-3/8	<b>131839</b>	P2B-SXRb-106	<b>068200</b>	P2B-SXRb-106-FF
	1-7/16	<b>131840</b>	P2B-SXRb-107	<b>068201</b>	P2B-SXRb-107-FF
	35mm	@	P2B-SXRb-35M	@	P2B-SXRb-35M-FF

Series	Shaft Size	Weight lbs. kg.	A	B	C	D		F Bolt Dia.	G	H	J	L	M	R	S	U	V	W	X	
						min.	max.													
203 (SXR)	1/2	1.2	1.47	5.00	1.20	3.25	4.06	3/8	0.84	0.47	2.14	1.13	1.06	0.55	0.92	2.25	4.50	0.38	0.12	
	5/8	1.0																		
	17mm	.5	37.3	127.0	30.5	82.6	103.1	M10	21.3	11.9	54.4	28.7	26.9	14.0	23.4	57.2	114.3	9.7	3.0	
204	3/4	1.5	1.55	5.25	1.34	3.38	4.19	3/8	0.85	0.47	2.49	1.31	1.25	0.50	1.05	2.25	4.50	0.50	0.12	
	20mm	.7	39.4	133.4	34.0	85.9	106.4	M10	21.6	11.9	63.2	33.3	31.8	12.7	26.7	57.2	114.3	12.7	3.0	
205	7/8	1.8	1.62	5.50	1.40	3.69	4.50	3/8	0.85	0.45	2.64	1.50	1.31	0.56	1.06	2.50	5.00	0.50	0.12	
	15/16	1.7																		
	1	1.6																		
	25mm	.8	41.1	139.7	35.6	93.7	114.3	M10	21.6	11.4	67.1	38.1	33.3	14.2	26.9	63.5	127.0	12.7	3.0	
206	1-1/16	2.7	1.77	6.25	1.75	4.25	5.00	1/2	0.94	0.62	3.19	1.75	1.56	0.58	1.19	2.88	5.76	0.56	0.12	
	1-1/8	2.6																		
	1-3/16	2.5																		
	1-1/4	2.4																		
	30mm	1.1	45.0	158.8	44.5	108.0	127.0	M12	23.9	15.8	81.0	44.5	39.6	14.7	30.2	73.2	146.3	14.2	3.0	
207	1-1/4	4.4	1.95	6.50	1.75	4.68	5.44	1/2	0.94	0.65	3.69	2.13	1.81	0.67	1.28	2.91	5.82	0.56	0.12	
	1-5/16	4.3																		
	1-3/8	4.2																		
	1-7/16	4.1																		
	35mm	1.9	49.5	165.1	44.5	118.9	138.2	M12	23.9	16.5	93.7	54.1	46.0	17.0	32.5	73.9	147.8	14.2	3.0	